

# NH fuse-links gG 400VAC

double indicator/live gripping-lugs size 000, 00, 1, 2, 3

## LOW VOLTAGE IEC FUSES

### IEC NH FUSE-LINKS



The NH system is classified among plug-in fuse systems and is composed of:

- fuse-base (possibly including terminal covers and phase barriers)
- fuse-link with blade contact
- fuse-link replacement device (LV HRC fuse puller)

Since the design of this system cannot guarantee non-interchangeability of rated current it must be handled by a qualified professional.

Type “gG” NH fuse-links are full range breaking capacity fuse-links and are used to protect cables and equipment. They can interrupt any current surge, from the lowest fusing current up to their breaking capacity, and so can be used alone as protection. They also protect electrical devices and industrial set-ups from the electrodynamic effects of very high short-circuit currents.

Rated Power Dissipation values of Mersen NH fuse-links 400VAC are below the maximum values required by standard IEC 60269.

## TECHNICAL DATA OVERVIEW

Voltage AC	400 VAC
Ampere Range (A)	2 ... 630 A
Size per Standard	Sizes 000 to 3
Speed/Characteristic	gG
I.R. AC (IEC)	100 kA
Body Material	ceramic
Contact Materials	copper, silver-plated

## FEATURES & BENEFITS

- Dimensions according to DIN 43 620 Parts 1 to 4
- Non-isolated gripping lugs
- Double indicator
- Lead free contact blades
- 0% cadmium

## APPLICATIONS

- gG: general purpose cable and line protection

## STANDARDS

- VDE 0636 Part 201
- IEC 60269-1 and -2



# NH fuse-links gG 400VAC

double indicator/live gripping-lugs size 000, 00, 1, 2, 3

## PRODUCT RANGE



NH000GG40V35

### Size 000 gG 400VAC

Catalog number	Item number	Rated voltage AC (IEC)	Rated current I <sub>n</sub>	Power dissipation at I <sub>n</sub>	Width	Package	Weight
NH000GG40V2	Z223674	400 V	2 A	0.7 W	20.8 mm	3	0.13 kg
NH000GG40V4	A223675	400 V	4 A	0.9 W	20.8 mm	3	0.13 kg
NH000GG40V6	B223676	400 V	6 A	1.2 W	20.8 mm	3	0.13 kg
NH000GG40V10	C223677	400 V	10 A	1.3 W	20.8 mm	3	0.13 kg
NH000GG40V16	D223678	400 V	16 A	1.6 W	20.8 mm	9	0.13 kg
NH000GG40V20	E223679	400 V	20 A	1.9 W	20.8 mm	9	0.13 kg
NH000GG40V25	F223680	400 V	25 A	2.2 W	20.8 mm	9	0.13 kg
NH000GG40V32	G223681	400 V	32 A	2.7 W	20.8 mm	9	0.13 kg
NH000GG40V35	H223682	400 V	35 A	3.1 W	20.8 mm	9	0.13 kg
NH000GG40V40	J223683	400 V	40 A	3.5 W	20.8 mm	9	0.13 kg
NH000GG40V50	K223684	400 V	50 A	3.9 W	20.8 mm	9	0.13 kg
NH000GG40V63	L223685	400 V	63 A	5.2 W	20.8 mm	9	0.13 kg
NH000GG40V80	M223686	400 V	80 A	5.3 W	20.8 mm	9	0.13 kg
NH000GG40V100	N223687	400 V	100 A	5.7 W	20.8 mm	9	0.13 kg



NH00GG40V160

### Size 00 gG 400VAC

Catalog number	Item number	Rated voltage AC (IEC)	Rated current I <sub>n</sub>	Power dissipation at I <sub>n</sub>	Width	Package	Weight
NH00GG40V125	E223702	400 V	125 A	7.4 W	29.5 mm	3	0.2 kg
NH00GG40V160	F223703	400 V	160 A	8.3 W	29.5 mm	3	0.2 kg



NH1GG40V125

### Size 1 gG 400VAC

Catalog number	Item number	Rated voltage AC (IEC)	Rated current I <sub>n</sub>	Power dissipation at I <sub>n</sub>	Width	Package	Weight
NH1GG40V35	J223706	400 V	35 A	4 W	29.5 mm	3	0.28 kg
NH1GG40V50	K223707	400 V	50 A	5.2 W	29.5 mm	3	0.28 kg
NH1GG40V63	L223708	400 V	63 A	6.8 W	29.5 mm	3	0.28 kg
NH1GG40V80	M223709	400 V	80 A	6.2 W	29.5 mm	3	0.28 kg
NH1GG40V100	N223710	400 V	100 A	8.6 W	29.5 mm	3	0.28 kg
NH1GG40V125	P223711	400 V	125 A	9.8 W	29.5 mm	3	0.28 kg
NH1GG40V160	Q223712	400 V	160 A	12.4 W	39.5 mm	3	0.41 kg
NH1GG40V200	R223713	400 V	200 A	14.4 W	39.5 mm	3	0.41 kg
NH1GG40V224	S223714	400 V	224 A	15.6 W	39.5 mm	3	0.41 kg
NH1GG40V250	T223715	400 V	250 A	17.6 W	39.5 mm	3	0.41 kg



NH2GG40V250

### Size 2 gG 400VAC

Catalog number	Item number	Rated voltage AC (IEC)	Rated current I <sub>n</sub>	Power dissipation at I <sub>n</sub>	Width	Package	Weight
NH2GG40V35	T227257	400 V	35 A	4.1 W	29.5 mm	3	0.42 kg
NH2GG40V50	V227258	400 V	50 A	5.4 W	29.5 mm	3	0.42 kg
NH2GG40V63	W227259	400 V	63 A	6.8 W	29.5 mm	3	0.42 kg
NH2GG40V80	F223726	400 V	80 A	6.4 W	29.5 mm	3	0.42 kg
NH2GG40V100	G223727	400 V	100 A	8.1 W	29.5 mm	3	0.42 kg
NH2GG40V125	H223728	400 V	125 A	10.2 W	29.5 mm	3	0.42 kg
NH2GG40V160	J223729	400 V	160 A	10.8 W	29.5 mm	3	0.42 kg
NH2GG40V200	K223730	400 V	200 A	15.2 W	29.5 mm	3	0.42 kg
NH2GG40V224	L223731	400 V	224 A	14.7 W	29.5 mm	3	0.42 kg
NH2GG40V250	M223732	400 V	250 A	17.1 W	29.5 mm	3	0.42 kg
NH2GG40V315	N223733	400 V	315 A	20.1 W	39.5 mm	3	0.64 kg
NH2GG40V355	P223734	400 V	355 A	22.6 W	39.5 mm	3	0.64 kg
NH2GG40V400	Q223735	400 V	400 A	25.4 W	39.5 mm	3	0.64 kg



# NH fuse-links gG 400VAC

double indicator/live gripping-lugs size 000, 00, 1, 2, 3

## PRODUCT RANGE

### Size 3 gG 400VAC

Catalog number	Item number	Rated voltage AC (IEC)	Rated current $I_n$	Power dissipation at $I_n$	Width	Package	Weight
NH3GG40V250	R223736	400 V	250 A	15.4 W	39.5 mm	1	0.65 kg
NH3GG40V315	S223737	400 V	315 A	19.8 W	39.5 mm	1	0.65 kg
NH3GG40V400	T223738	400 V	400 A	25.1 W	39.5 mm	1	1.05 kg
NH3GG40V500	V223739	400 V	500 A	31.1 W	51 mm	1	1.05 kg
NH3GG40V630	W223740	400 V	630 A	39 W	51 mm	1	1.05 kg

## TECHNICAL DATA

	Size 000 gG 400VAC	Size 00 gG 400VAC	Size 1 gG 400VAC	Size 2 gG 400VAC	Size 3 gG 400VAC
Rated current	2 ... 100 A	125 ... 160 A	35 ... 250 A	35 ... 400 A	250 ... 630 A
Rated breaking capacity AC	100 kA	100 kA	100 kA	100 kA	100 kA
Rated voltage AC	400 V	400 V	400 V	400 V	400 V
Indication System	double indicator	double indicator	double indicator	double indicator	double indicator
Width	21 mm	30 mm	40 mm	51 mm	70 mm



## TIME CURRENT CHARACTERISTIC CURVES

Size 000

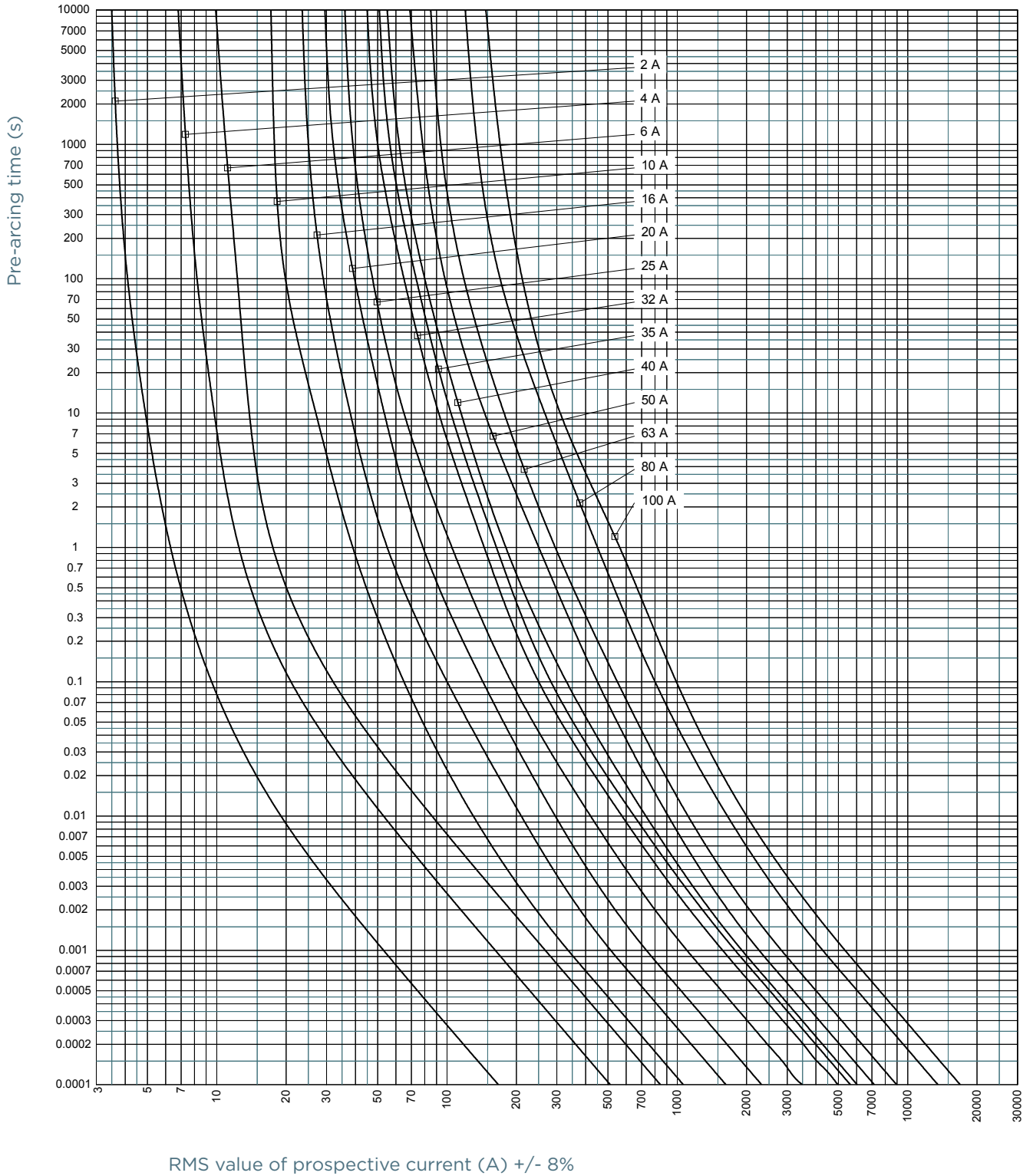

TIME CURRENT CHARACTERISTIC CURVES

Size 00

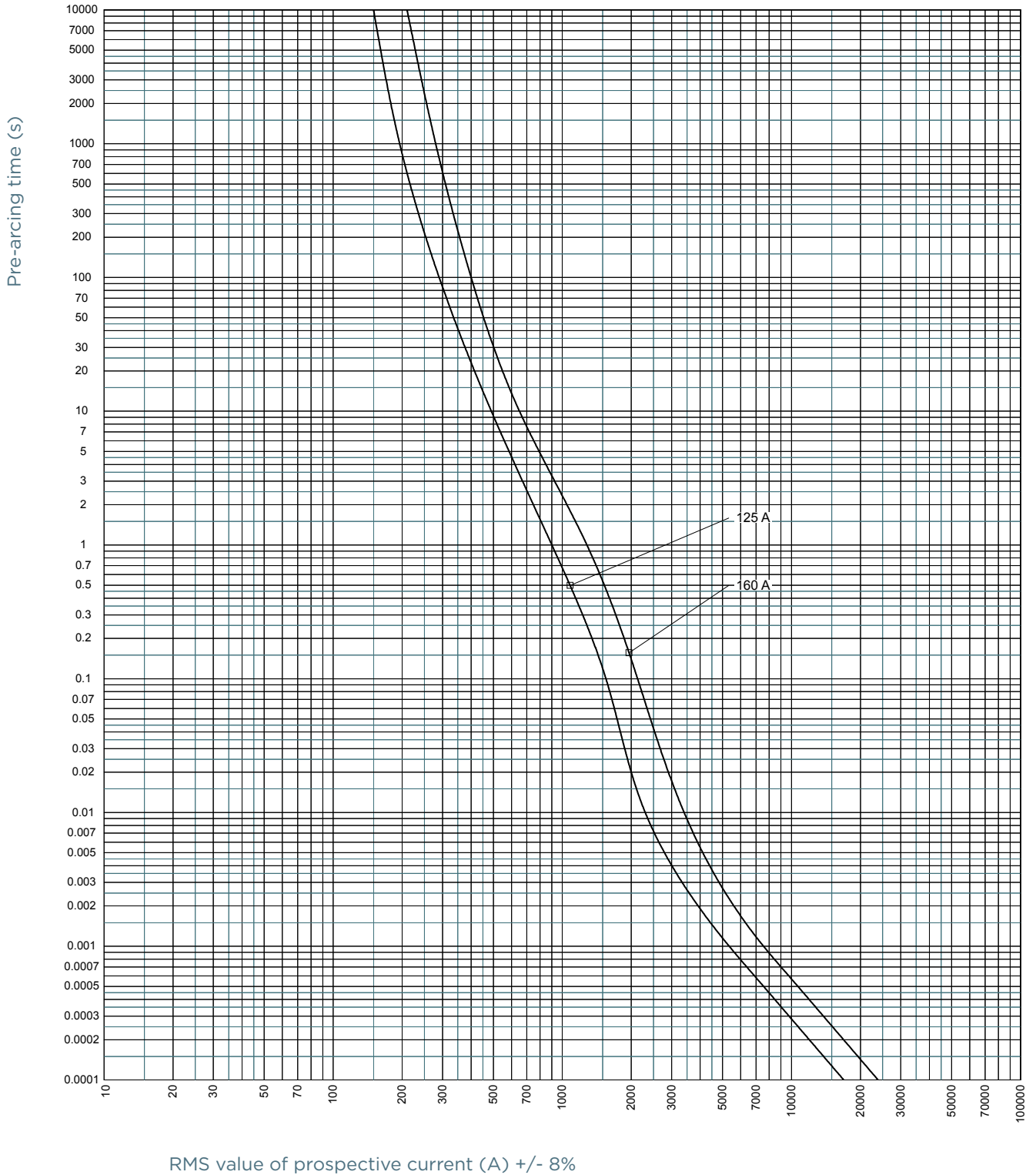

## TIME CURRENT CHARACTERISTIC CURVES

Size 1

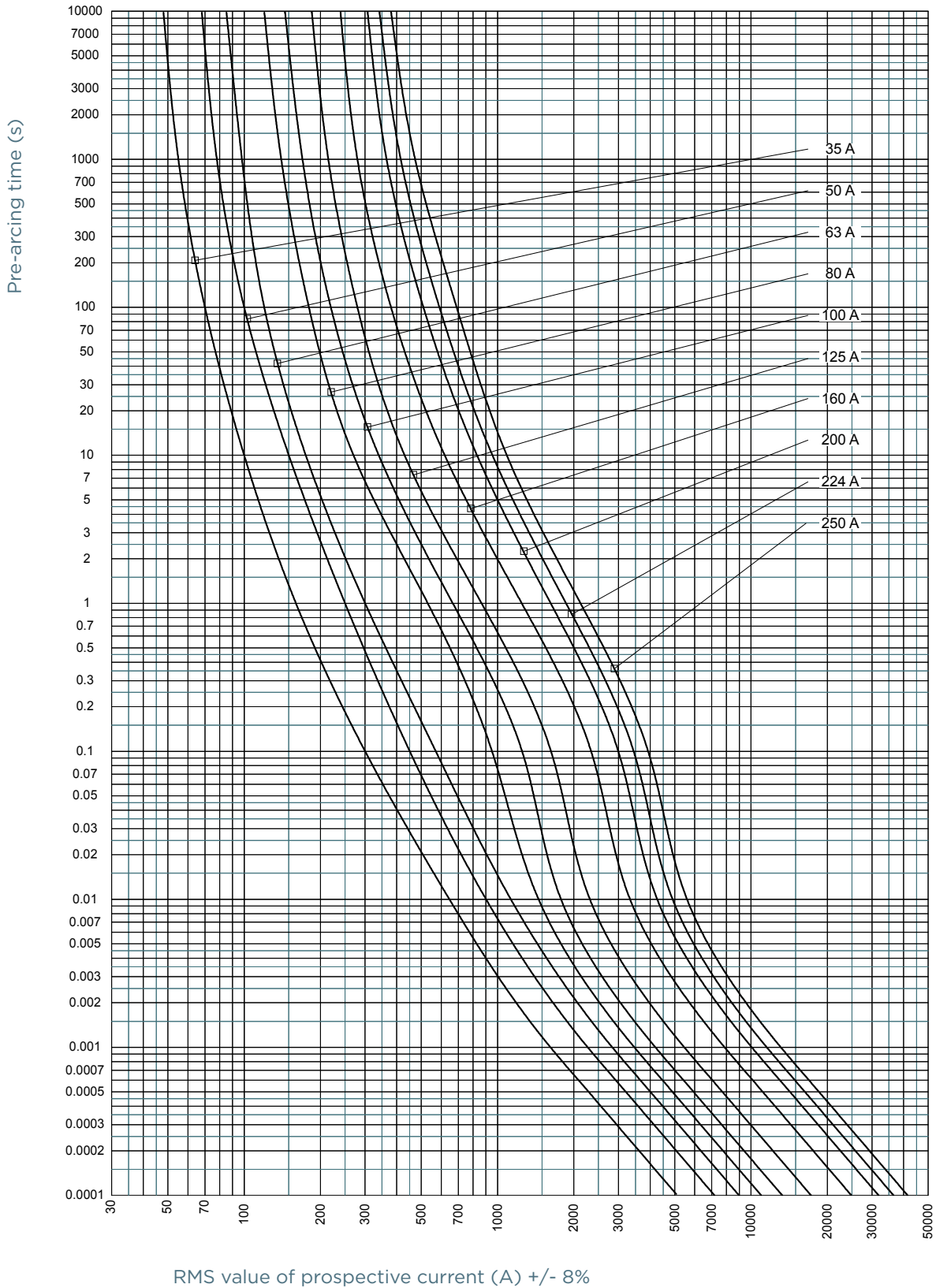

TIME CURRENT CHARACTERISTIC CURVES

Size 2

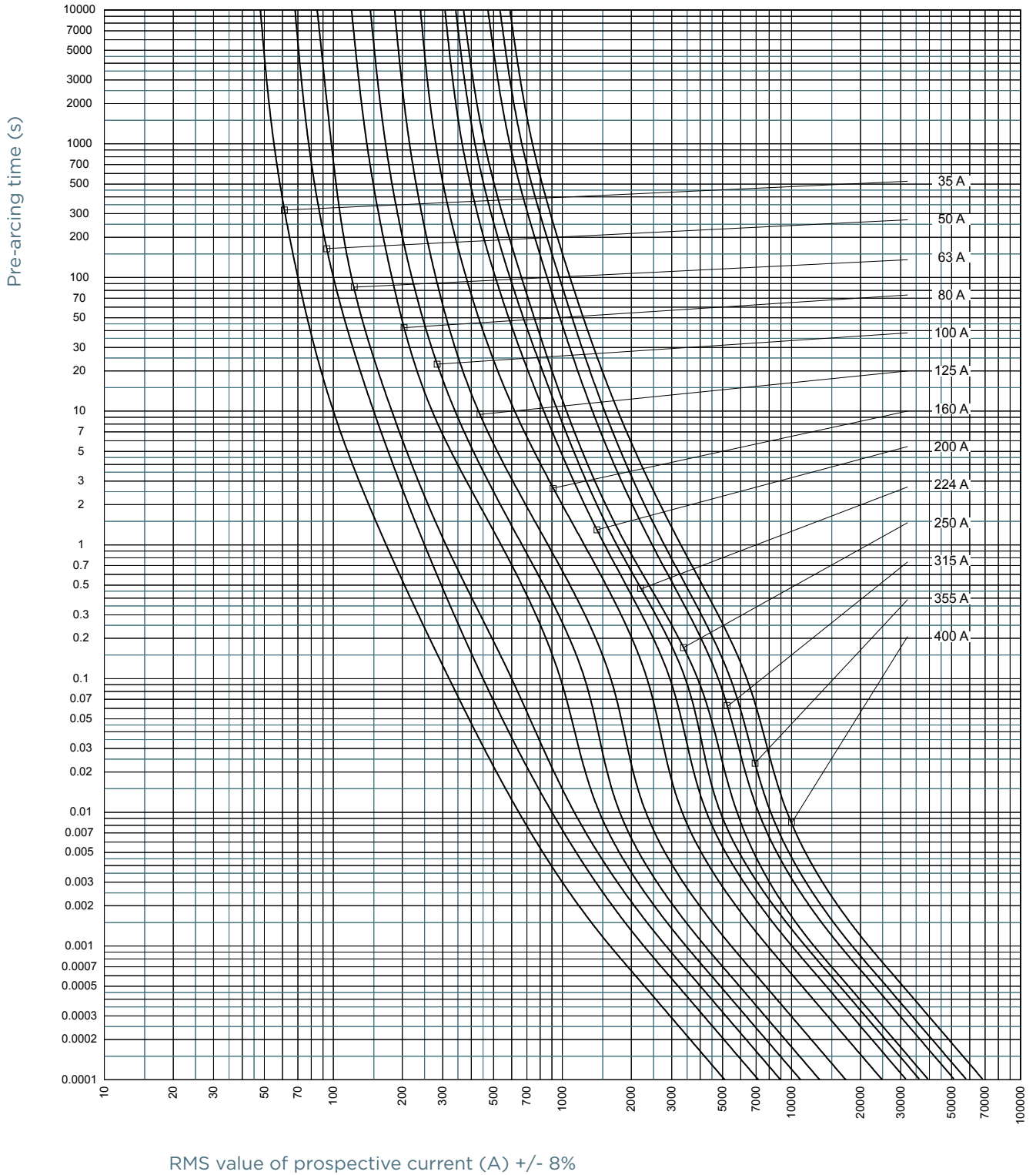

MERSEN reserves the right to change, update or correct, without notice, any information contained in this datasheet.

TIME CURRENT CHARACTERISTIC CURVES

Size 3

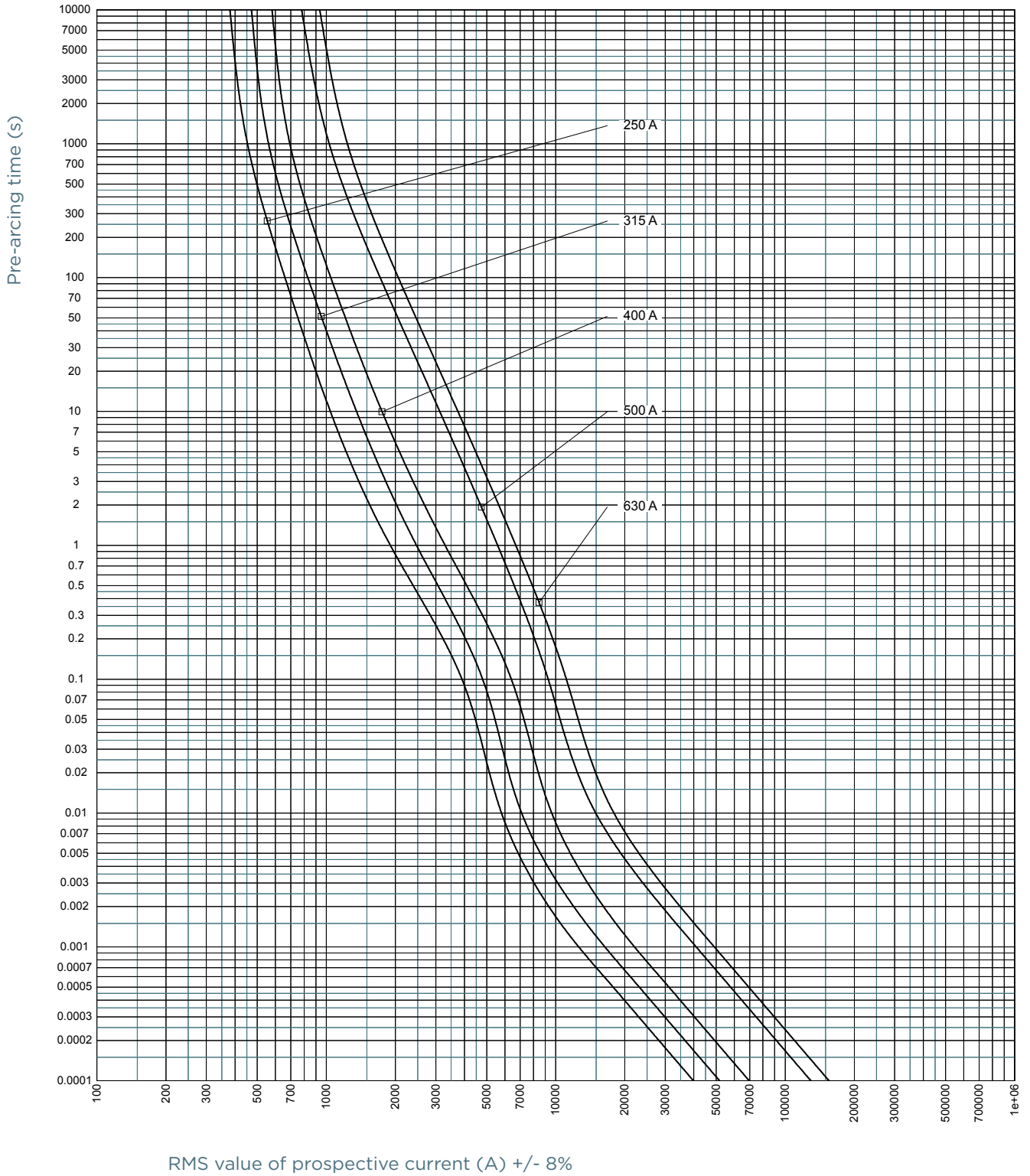

MERSEN reserves the right to change, update or correct, without notice, any information contained in this datasheet.



## CUT-OFF CURRENT CHARACTERISTIC

### Size 000

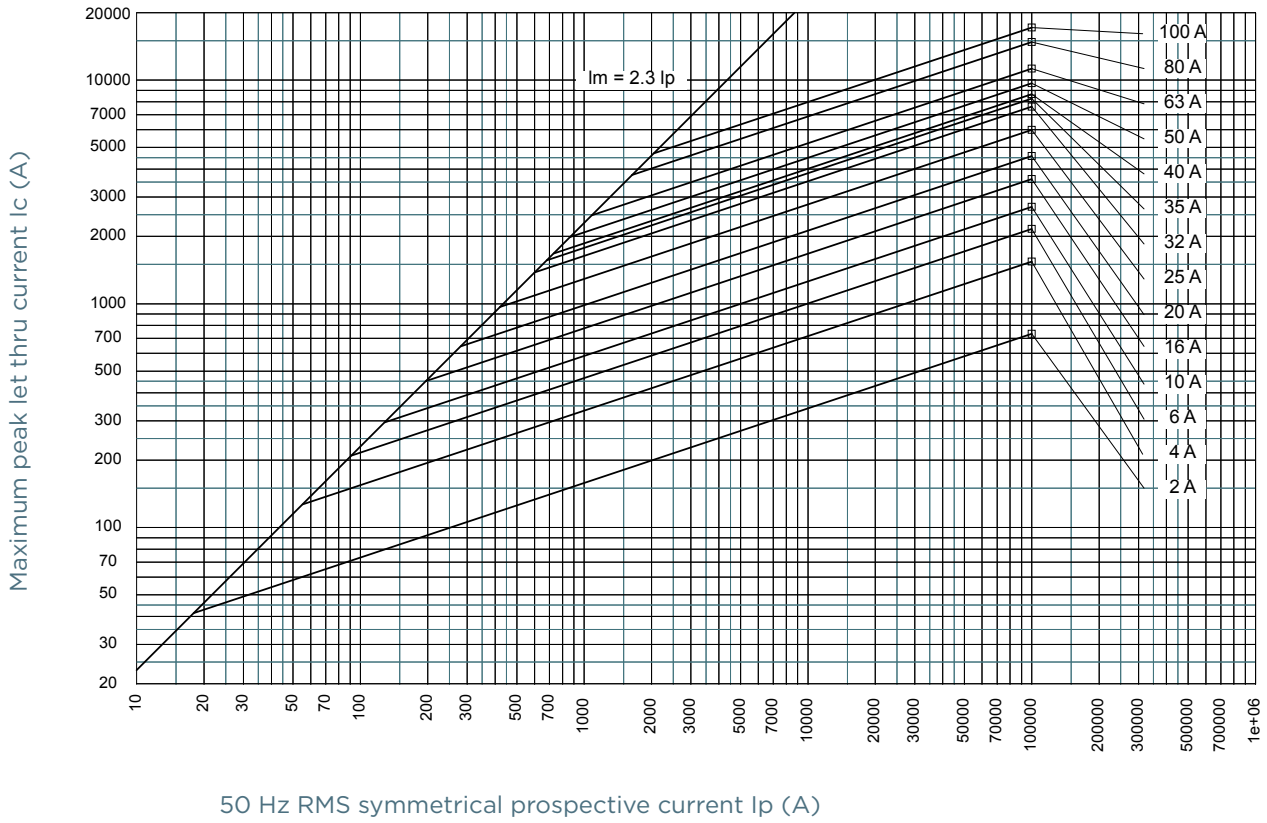

### Size 00

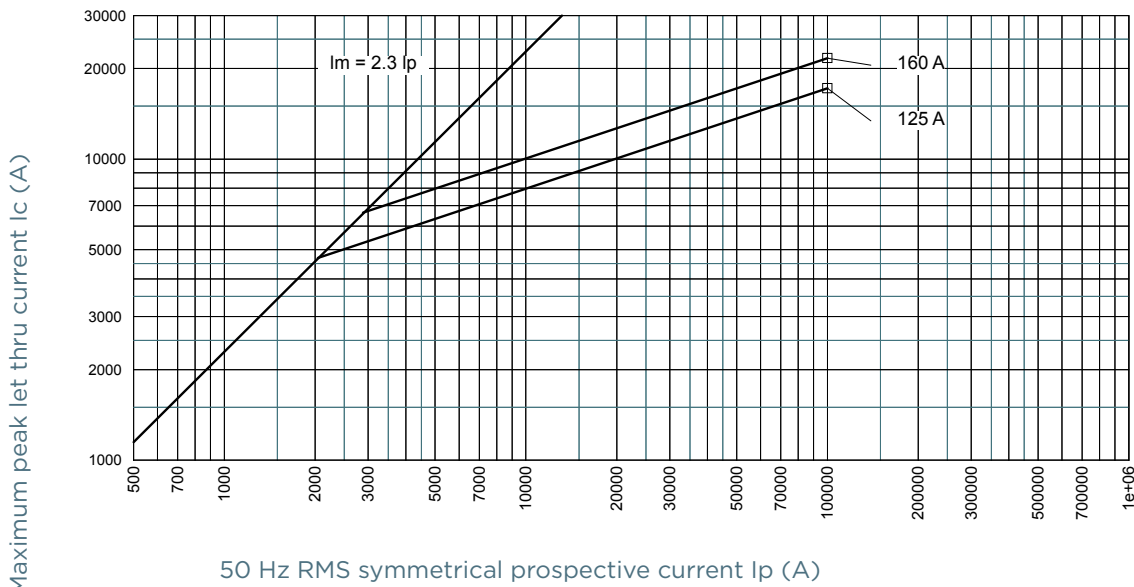

## CUT-OFF CURRENT CHARACTERISTIC

### Size 1

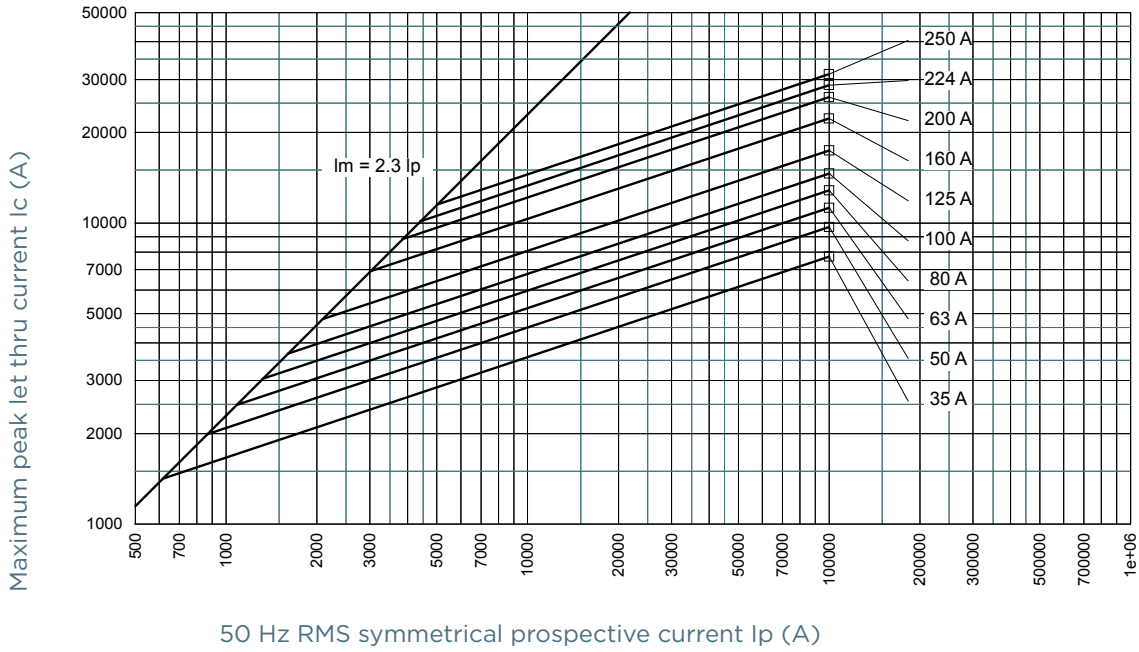

### Size 2

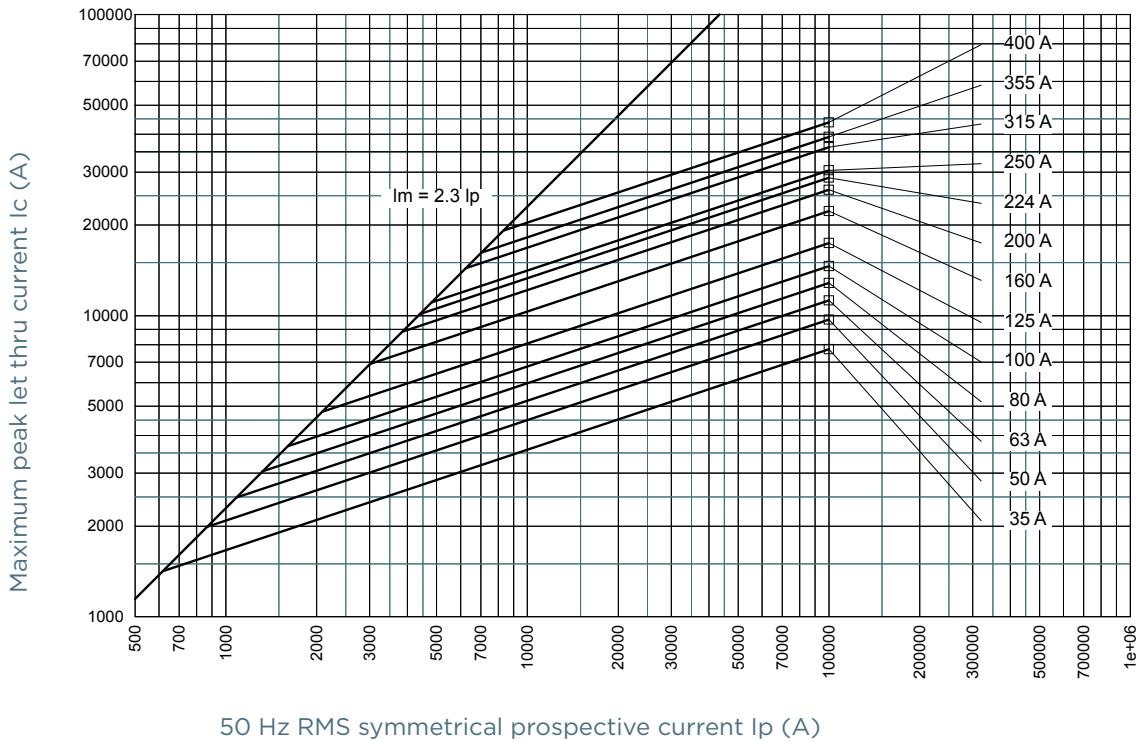

## CUT-OFF CURRENT CHARACTERISTIC

### Size 3

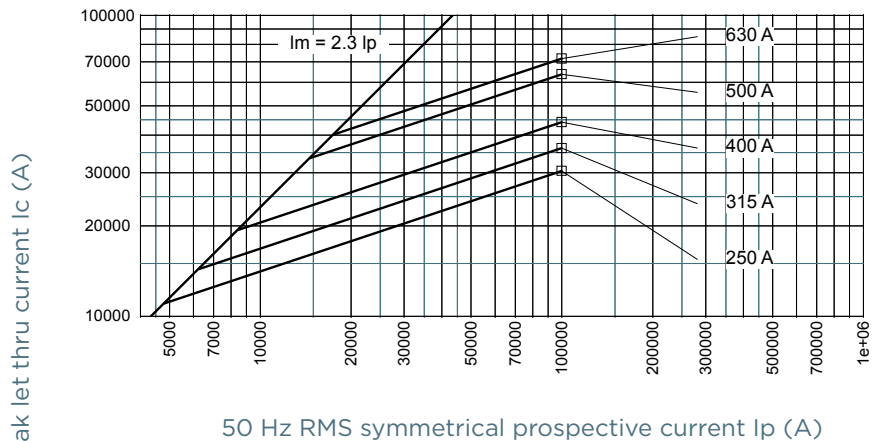

## PRE-ARCING AND OPERATING I<sup>2</sup>t CHARACTERISTICS

Size 000

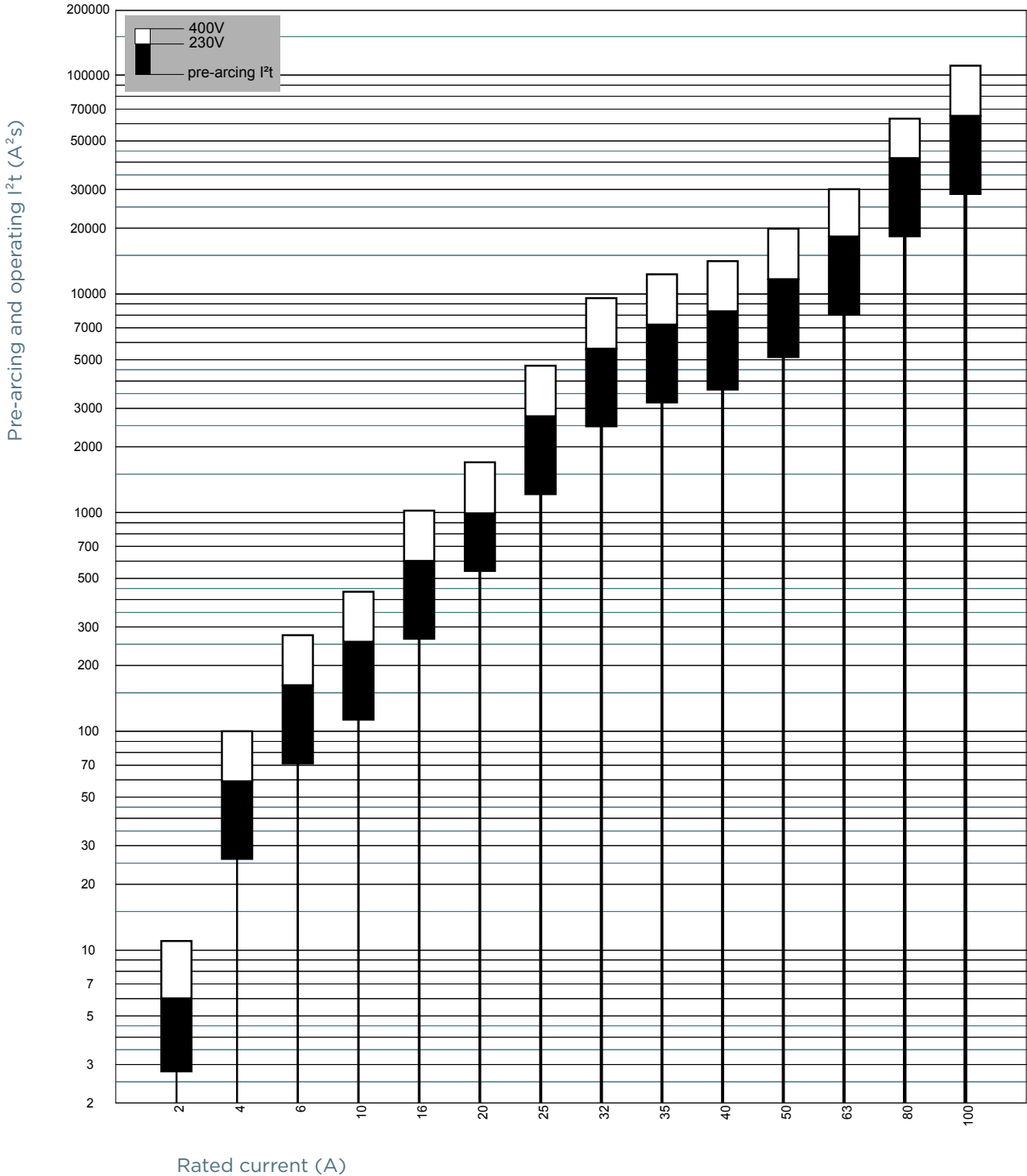

## PRE-ARCING AND OPERATING I<sup>2</sup>t CHARACTERISTICS

### Size 00

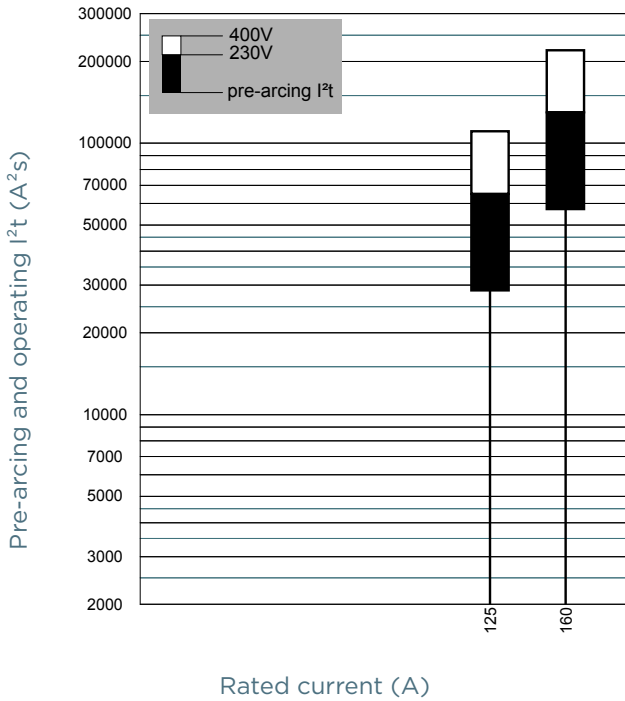

### Size 1

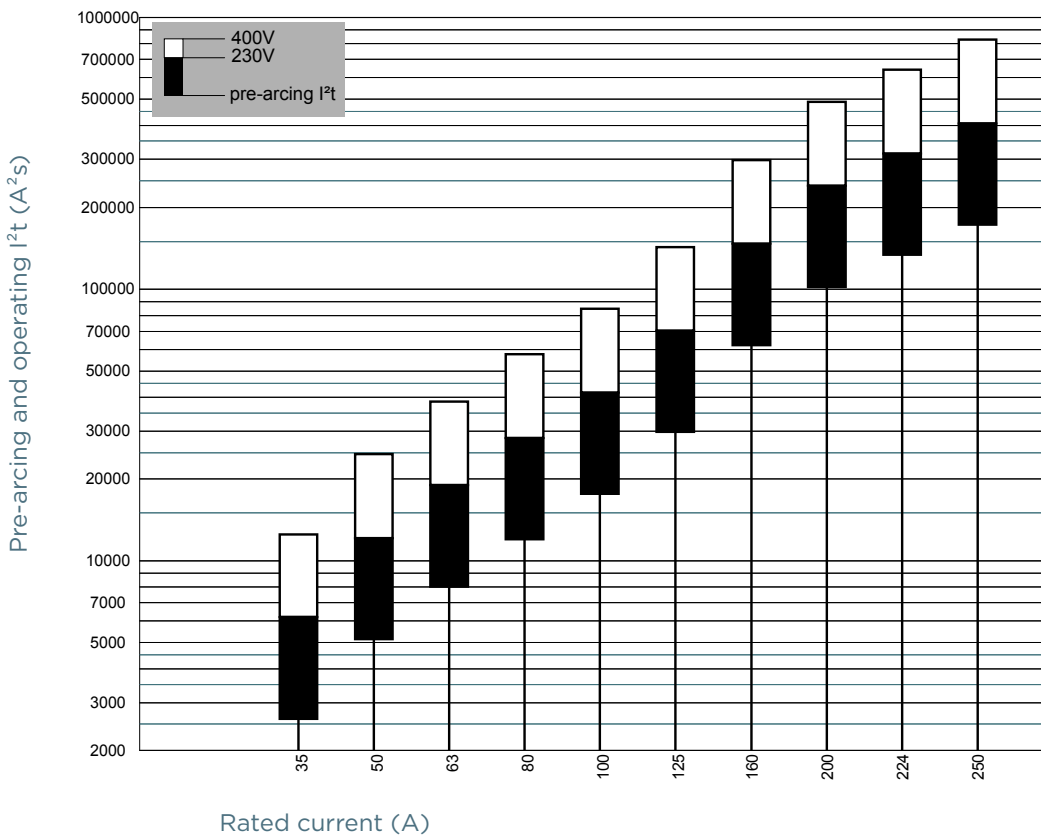

## PRE-ARCING AND OPERATING I<sup>2</sup>t CHARACTERISTICS

Size 2

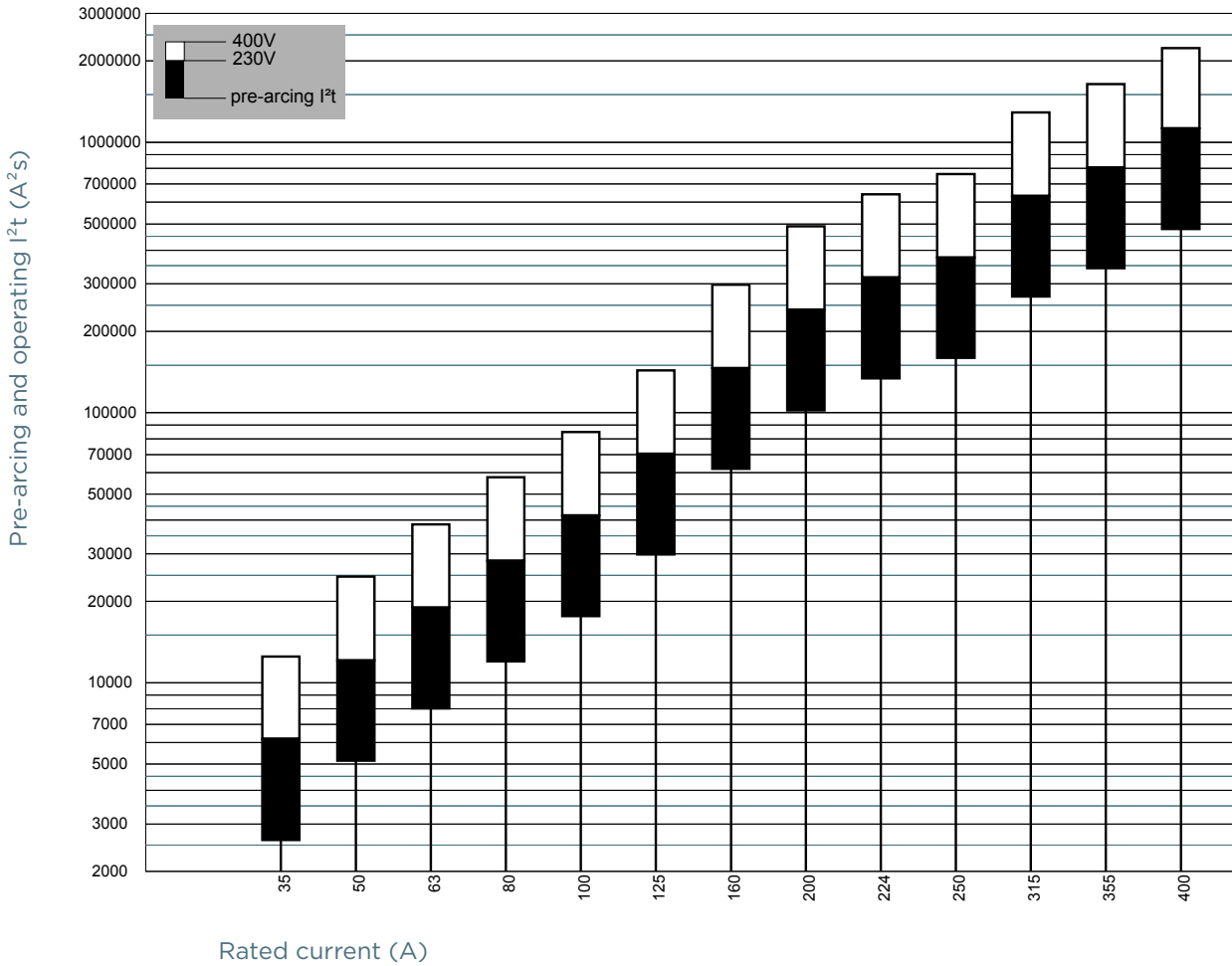

## PRE-ARCING AND OPERATING I<sup>2</sup>t CHARACTERISTICS

Size 3

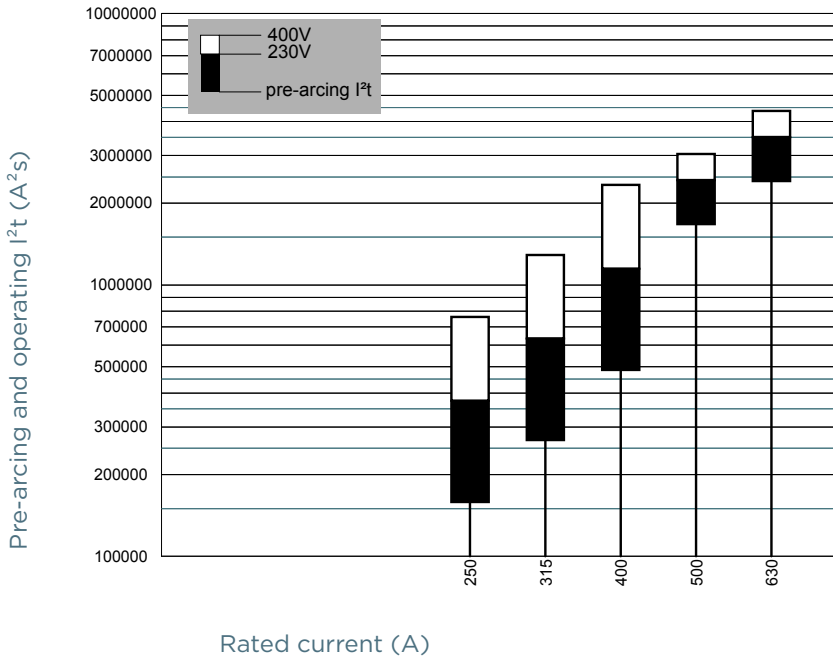

# NH fuse-links gG 400VAC

double indicator/live gripping-lugs size 000, 00, 1, 2, 3

## DIMENSIONS

Size 000 with double indicator (0118997C)

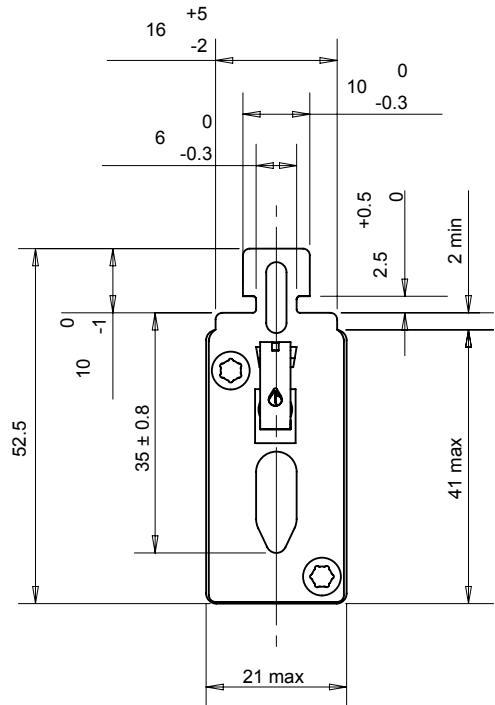
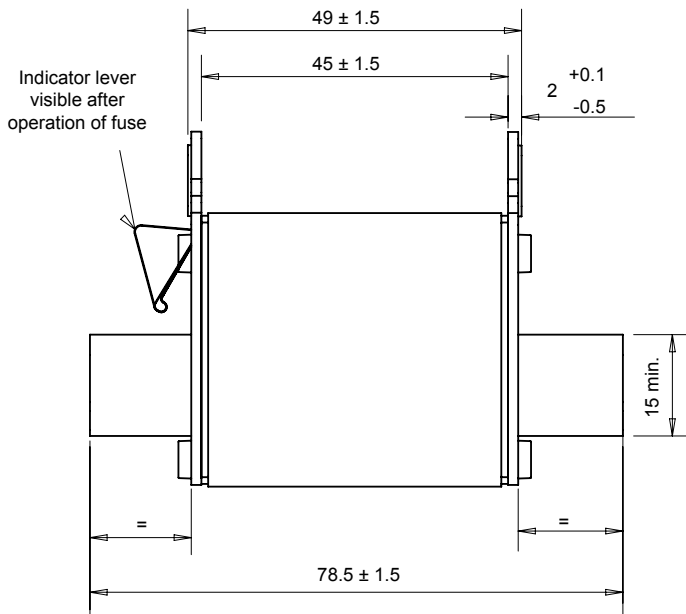

Visibility of red indicator signals conduction of the fuse-link.  
After operation the red indicator is no longer visible

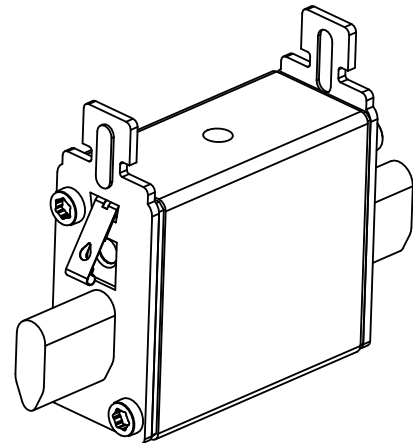
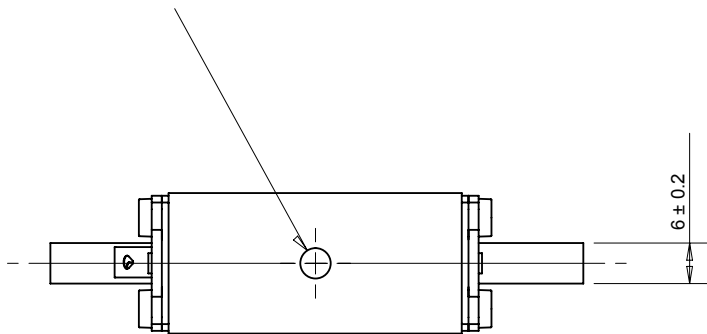

Dimensions in mm



# NH fuse-links gG 400VAC

double indicator/live gripping-lugs size 000, 00, 1, 2, 3

## DIMENSIONS

Size 00 with double indicator (118998 D)

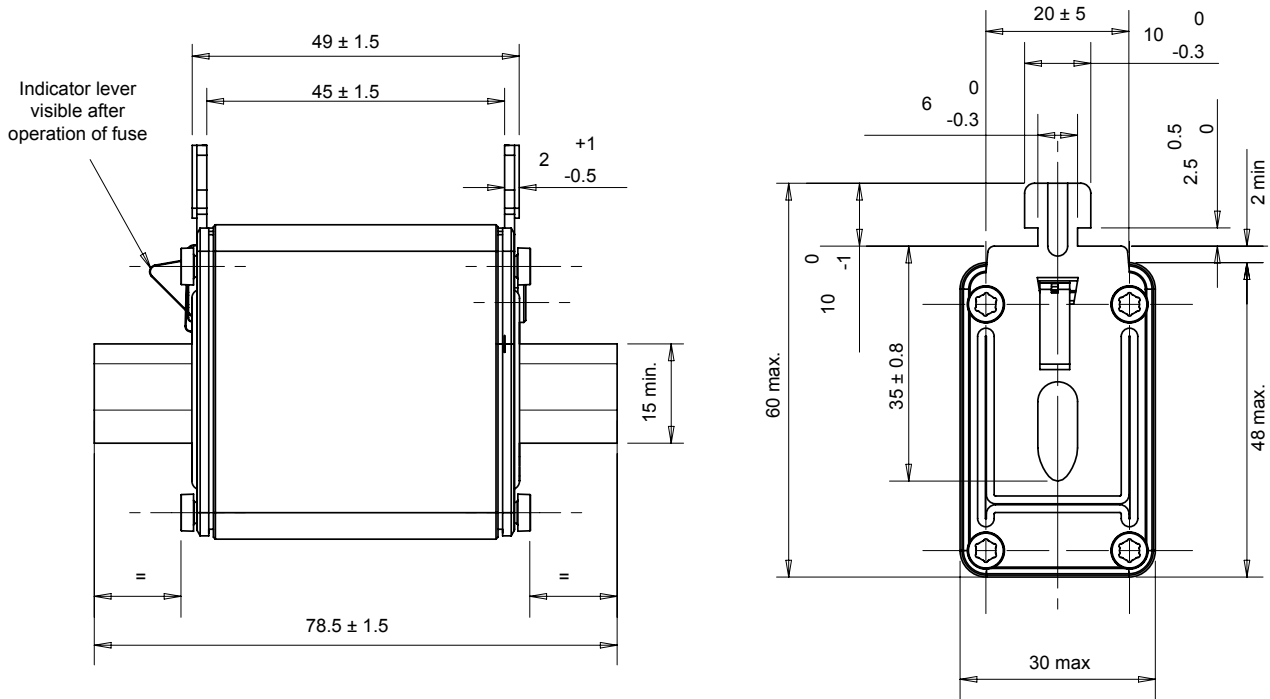

· Visibility of red indicator signals conduction of the fuse-link.  
After operation the red indicator is no longer visible

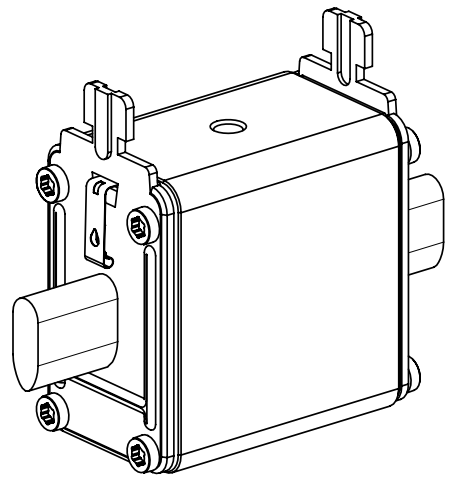
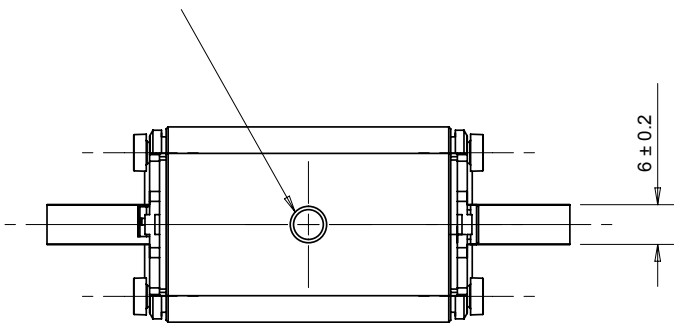

Dimensions in mm

# NH fuse-links gG 400VAC

double indicator/live gripping-lugs size 000, 00, 1, 2, 3

## DIMENSIONS

**Size 1 compact with double indicator (35-125A)** (1000413B)

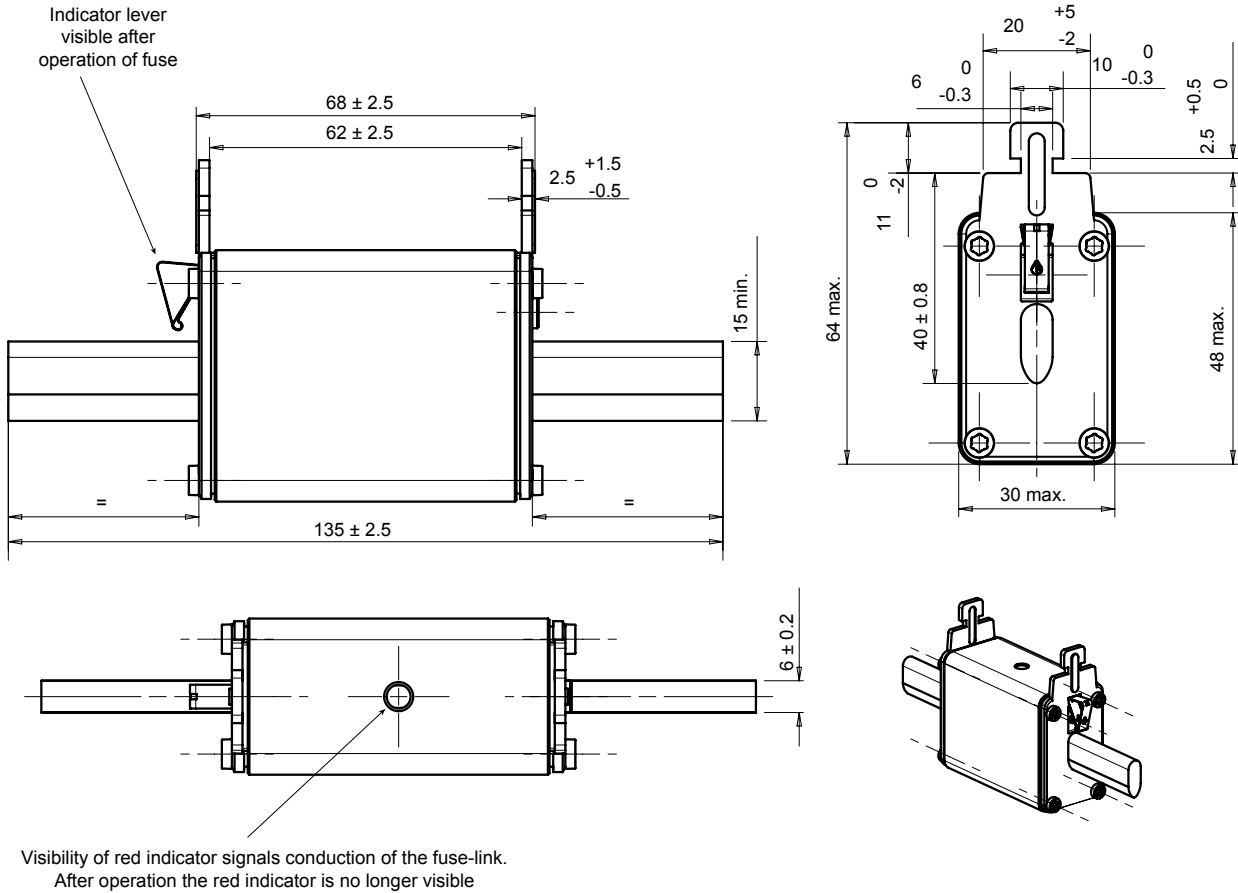

Dimensions in mm

# NH fuse-links gG 400VAC

double indicator/live gripping-lugs size 000, 00, 1, 2, 3

## DIMENSIONS

Size 1 with double indicator (160-250A) (118997 D)

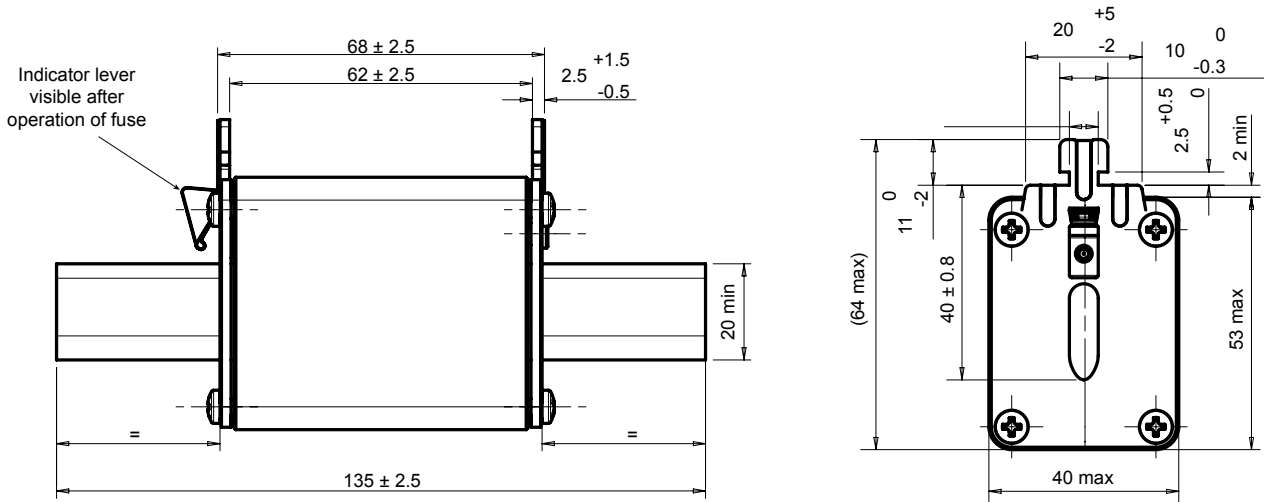

Visibility of red indicator signals conduction of the fuse-link.  
After operation the red indicator is no longer visible

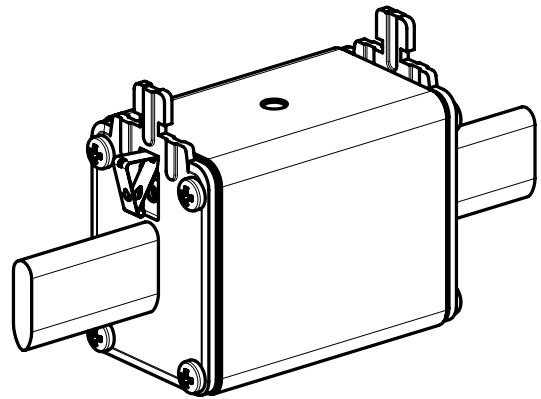
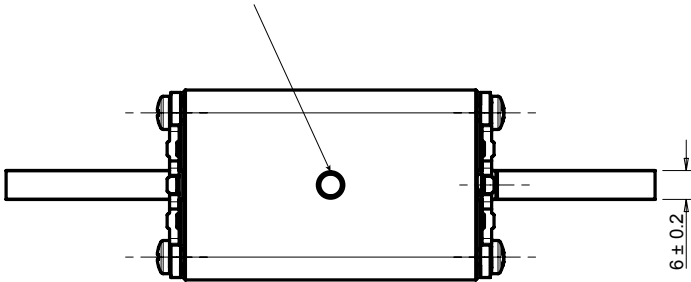

Dimensions in mm

# NH fuse-links gG 400VAC

double indicator/live gripping-lugs size 000, 00, 1, 2, 3

## DIMENSIONS

### Size 2 compact with double indicator (35-250A) (1000412C)

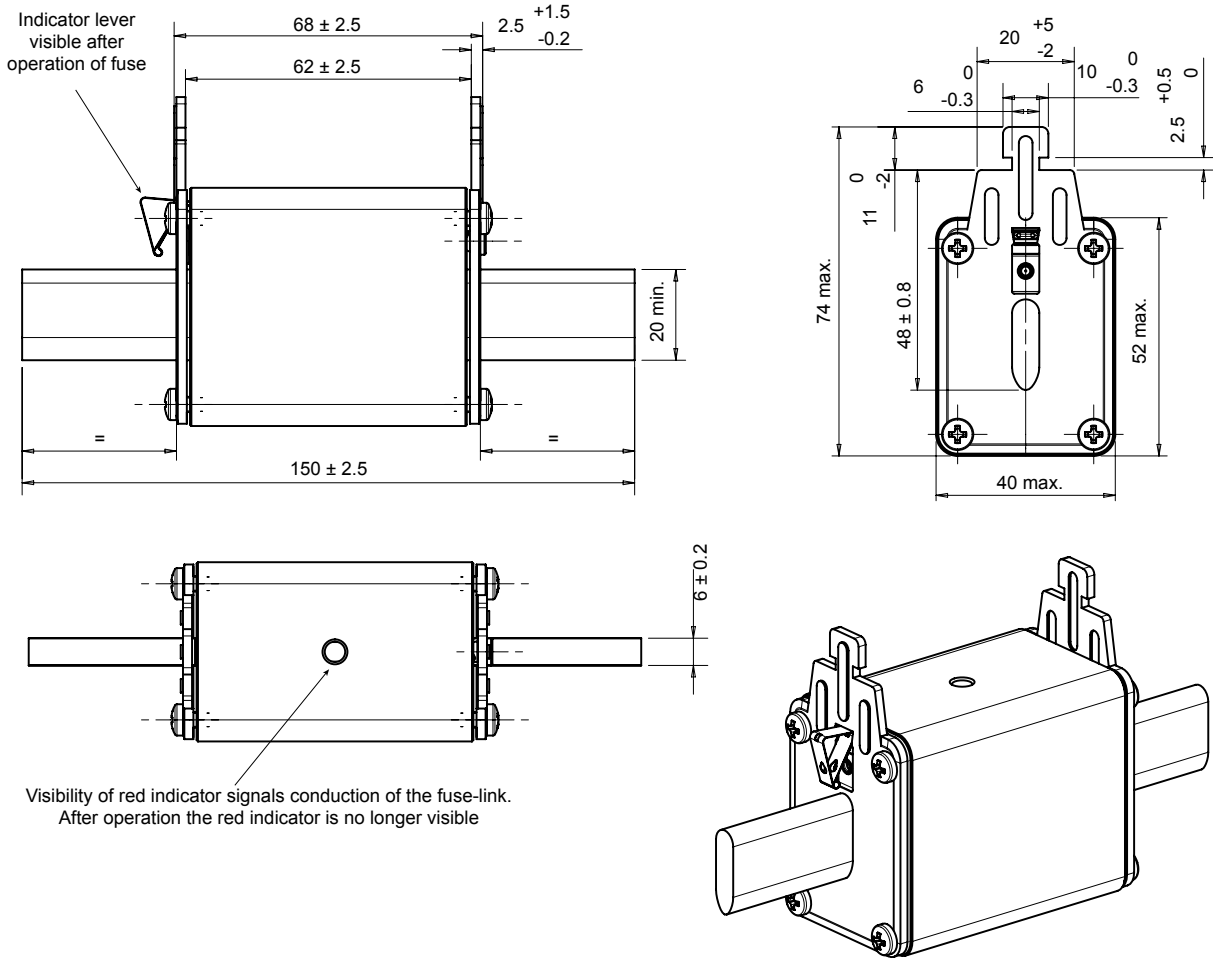

Dimensions in mm

# NH fuse-links gG 400VAC

double indicator/live gripping-lugs size 000, 00, 1, 2, 3

## DIMENSIONS

Size 2 with double indicator (315-400A) (119001 C)

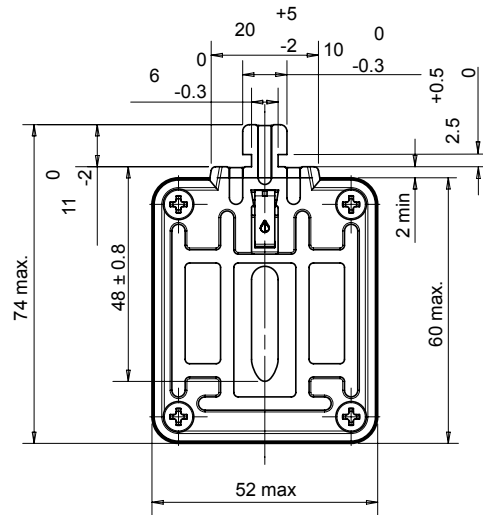
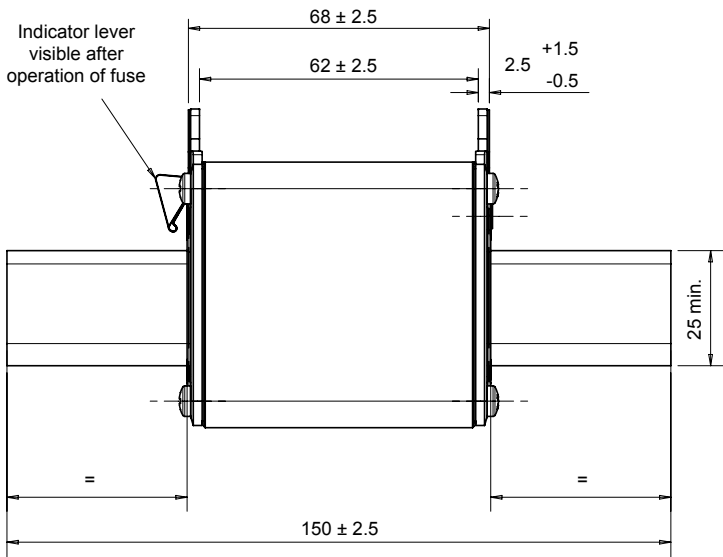

Visibility of red indicator signals conduction of the fuse-link.  
After operation the red indicator is no longer visible

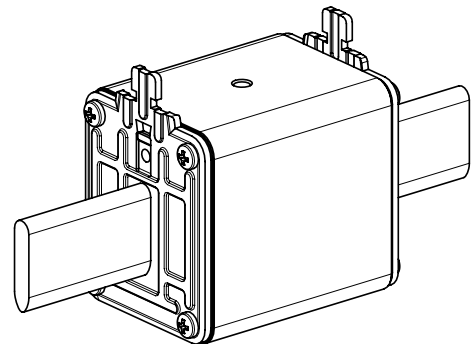
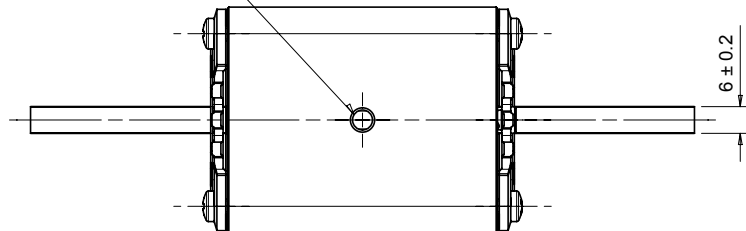

Dimensions in mm

# NH fuse-links gG 400VAC

double indicator/live gripping-lugs size 000, 00, 1, 2, 3

## DIMENSIONS

### Size 3 compact with double indicator (250-400A) (1000411B)

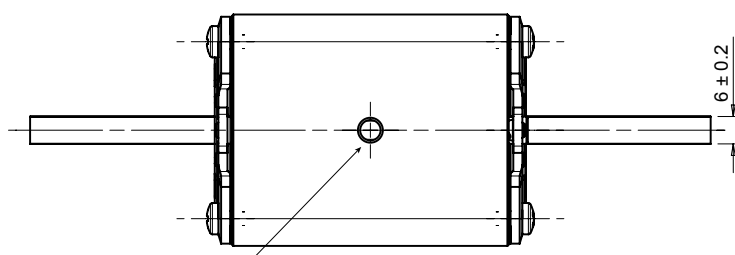
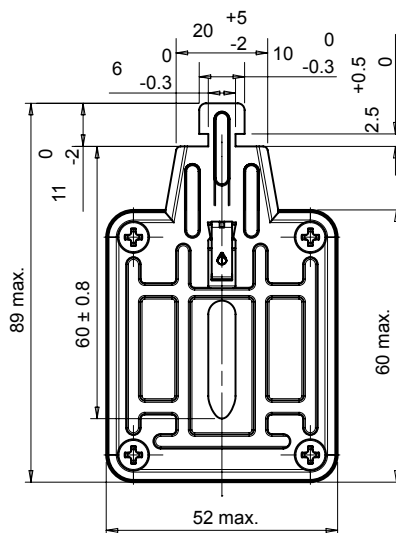
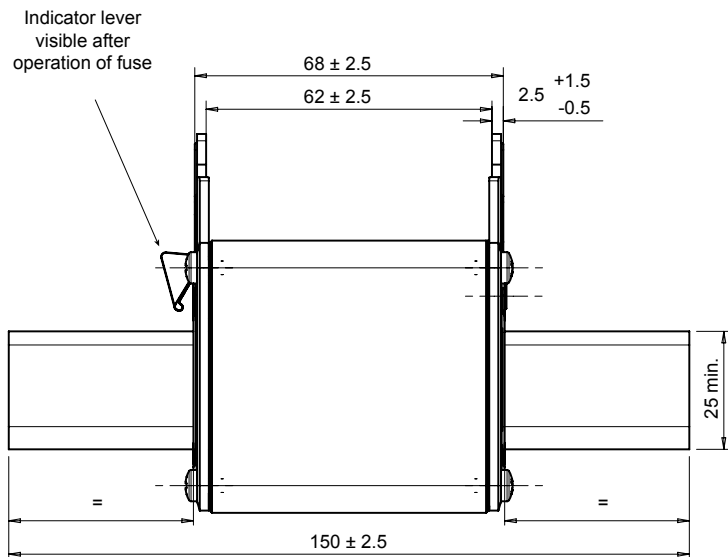

Visibility of red indicator signals conduction of the fuse-link.  
After operation the red indicator is no longer visible

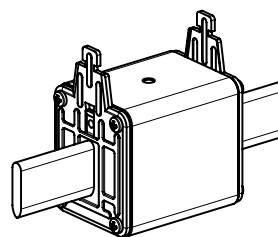

Dimensions in mm

# NH fuse-links gG 400VAC

double indicator/live gripping-lugs size 000, 00, 1, 2, 3

## DIMENSIONS

Size 3 with double indicator (500-630A) (119002 C)

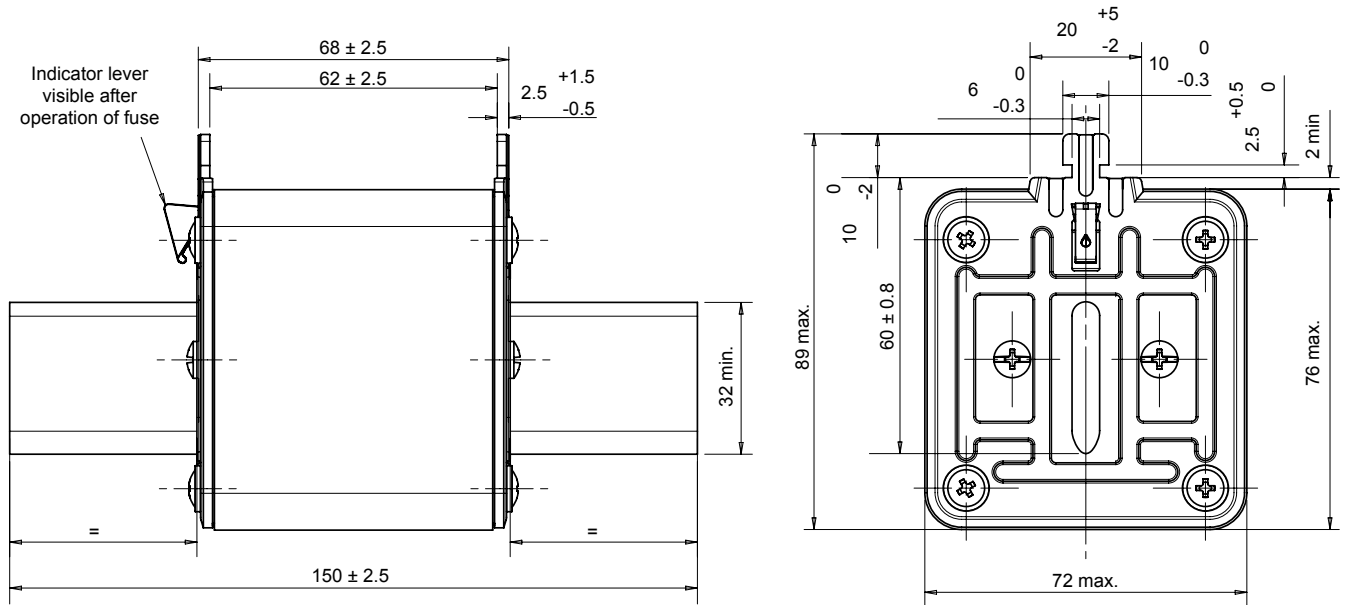

Visibility of red indicator signals conduction of the fuse-link.  
After operation the red indicator is no longer visible

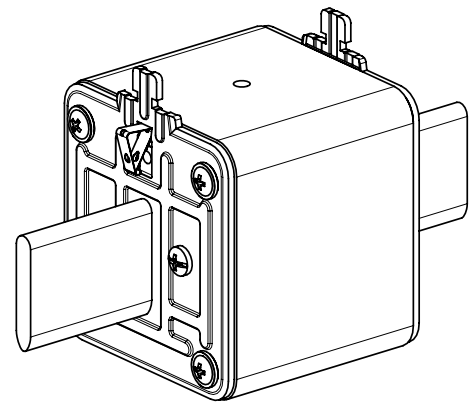
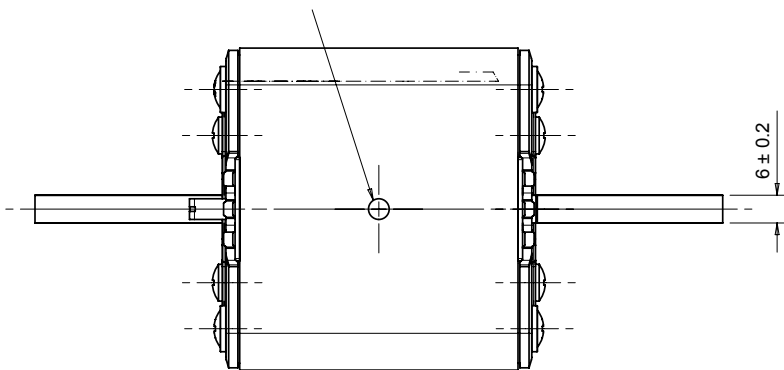

Dimensions in mm